

Burundi: The Heartbeat of Africa

An AI-Assisted Cultural Expedition

Cast Panel

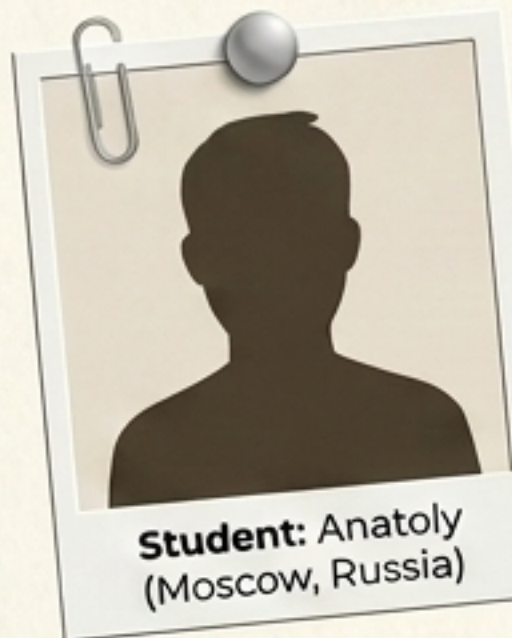

Source Material: AI-generated
destination primer.

*Fact-checked and
brought to life
during an Engoo.com
English lesson on
09/05/2026.*

Anatoly's Perspective

Accountant from Moscow. AI enthusiast.

Brings a pristine, AI-generated slide deck containing geographical and cultural data about Burundi.

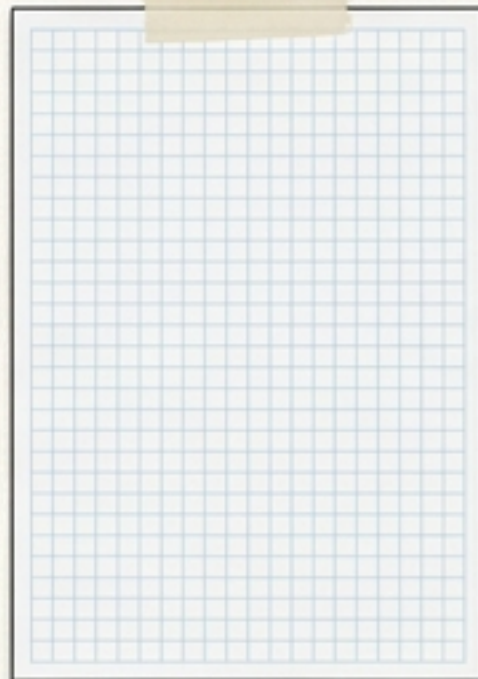
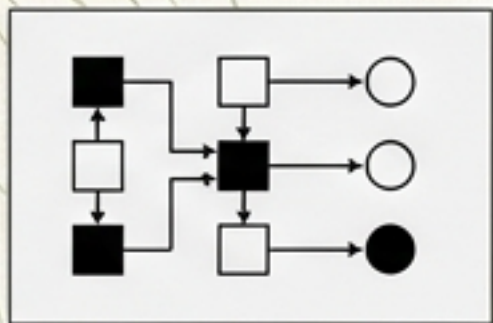
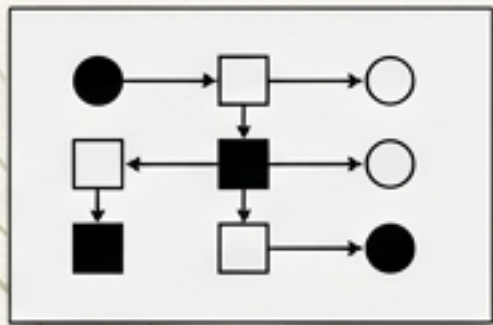

Gisita's Reality

Engoo tutor living in Bujumbura. Highly social, movie lover.

Brings the lived experience, clarifying the AI's data with warmth, nuance, and historical context.

Local Markets! 😊

Community Gatherings ❤️

Daily Life ❤️

My grandmother's stories...

Warm, welcoming people.

The market is huge!

It's more complex than that!

Landlocked nation;
population 14.7 million.
No ocean coast.

6 hours by bus
from
Bujumbura.

Democratic
Republic of
the Congo

Burundi

Tanzania

Lake
Tanganyika

Very close
to Uvira.

Less than 3
hours by flight;
6 hours to the
border.

Altitude Ecology Scale



Safety Warning

Filled with hipopotamuses and crocodiles. By law, we are not allowed to swim here!

Modern Unity

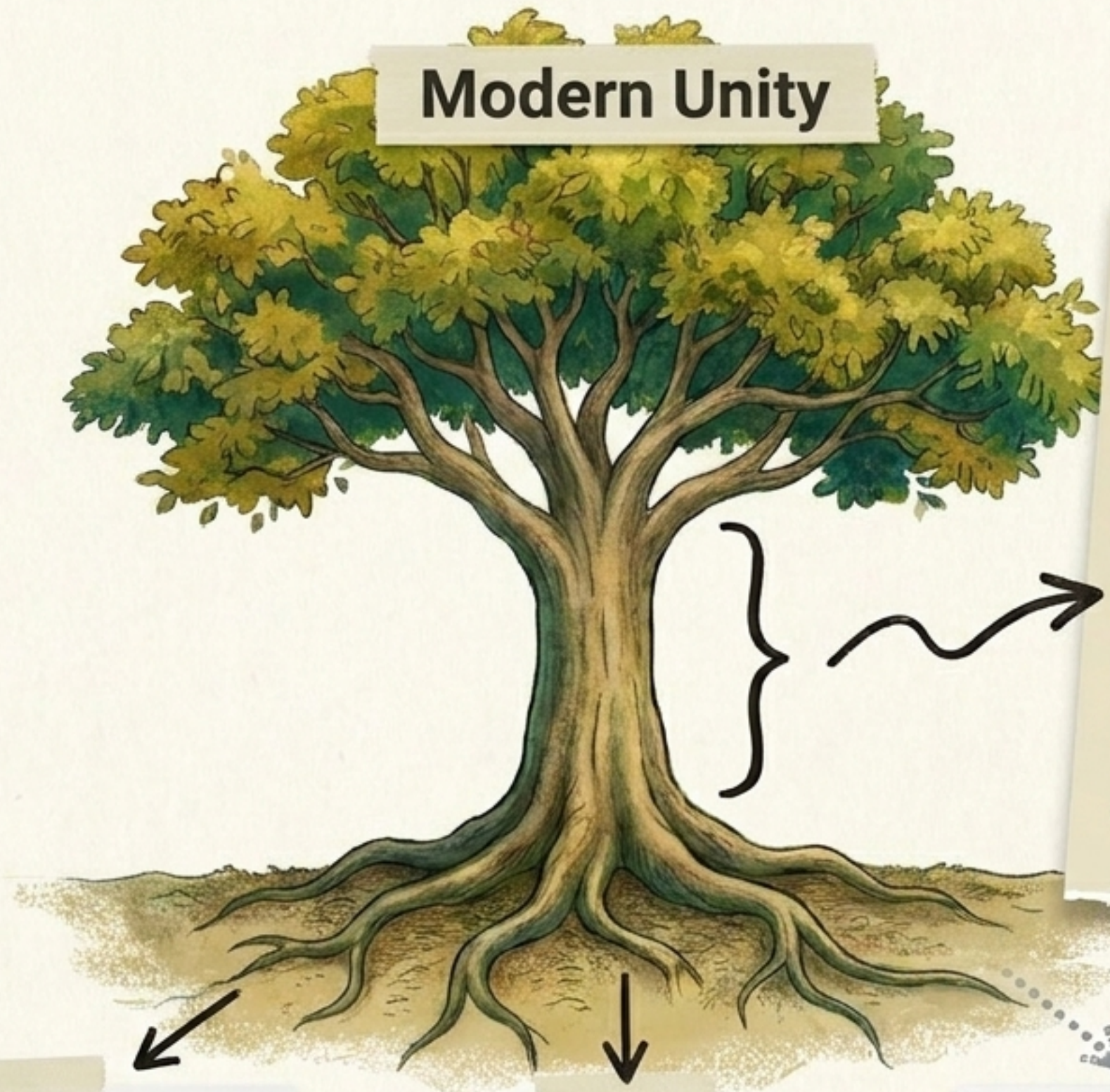

We are not different tribes, but ethnicities. We share 100% the same language (Kirundi), same food, and same geographic home.

Bantus / Hutu:
Vast majority, primarily agriculturalists.

Tutsi:
Traditional cattle-herders.

Twa:
Hunter-gatherers (very low percentage).

Modern Pride



Imvutano
(Traditional attire for men)

Echoes of Royalty

Way before colonialism and democracy—more than 600 years ago—the country was ruled through royal kingship. We still keep our culture and heritage of royalty today.

Anatomy of a Drum Circle



Center Drum (Inkiranya):
The leader / authority.
Commands the voice and
sets the flow.

Base Drums (Amashako):
The foundation. Provides
the continuous, steady
heartbeat.

Supporting Drums (Ibishikiso):
The followers.
Respond to the center and
add texture.

*Drumming is not learned
for fun; it is a sacred
inheritance passed from
father to son.*



Core Concept Output
Recognized as UNESCO
Intangible Cultural
Heritage—the literal pulse
of the nation.



**The umuvugangoma
(fig tree) origin story:**
Cutting the tree
requires special rituals
to honor the earth.

We do not really practice
cutting the tree with
these rituals today.
However, the drum still
completely represents
our heritage and
history.

The Hills



Tea Cultivation:
High-altitude, rolling
hills provide the
perfect climate.

The Home



The kweto (Traditional
Coffee Ceremony): A ritual
of roasting, brewing, and
serving that celebrates
hospitality.

*We are a very hilly
country, and we are
one of the biggest
exporters of coffee
in Africa.*

The Coffee Regions Matrix

	Kayanza	Ngozi	Muyinga
Altitude	Highest	Mid-high	Diverse microclimates
Flavor Profile	Bright acidity, floral, red fruits	Balanced acidity, citrus, caramel	Lively acidity, berry, cocoa
Best Processing Method	Washed	Natural	Both

If you travel to these provinces, you will definitely find most of the plantations.

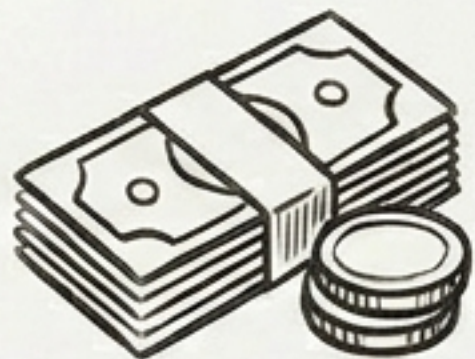

Burundian Franc (BIF).
USD cash recommended.













Visa on Arrival (VOA)
at Bujumbura Airport.



Kirundi & French
(primary). Swahili is
highly helpful.
English is growing but
less common.

*Let me assure
you—you
need a lot of
money [cash]!*

Getting Around: The Transit Matrix

 Matatus (Minibuses)	Speed: Medium (dial halfway) 	Cost: Low (one coin) 	Comfort: Low (crowded)	Use Case: Traveling set routes like a local.
 Boda-Bodas	Speed: Fast (dial high) 	Cost: Low (one coin) 	Comfort: Medium	Use Case: Quick, short-distance trips through town.
 Taxis / Tour Vehicles	Speed: Fast (dial high) 	Cost: High (three coins) 	Comfort: High	Use Case: Best for traveling outside the capital to rural attractions.
 Cost = Lowest	Cost = Lowest			

The cheapest of the cheapest, but I wouldn't guarantee your safety. I do not advise you take it.

Closing the Distance

Moscow:
Anatoly's
Classic
Tastes

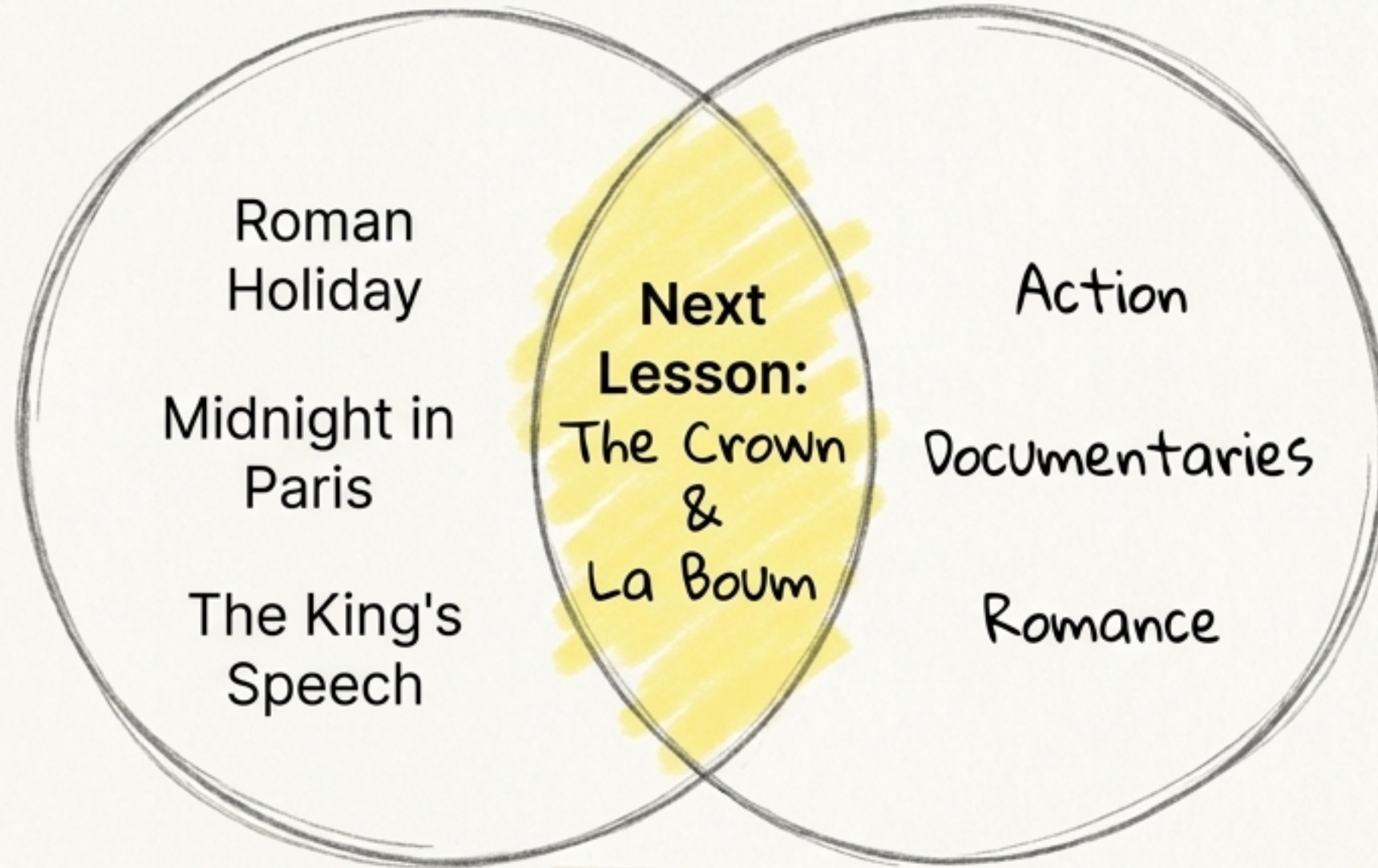

Bujumbura:
Gisita's
Dynamic
Tastes

Bridging 6,000 kilometers through
a shared love of storytelling.

Artificial Intelligence
(Can generate facts,
plot matrices, and map
borders instantly)

Lived Human
Experience
(Provides the warmth,
the safety warnings, and
the historical pride)

True Cultural
Understanding

*AI can build the presentation, but it takes
a human voice to find the heartbeat.*